

SANYO

INSTRUCTION MANUAL

VPC-T850

Digital Camera

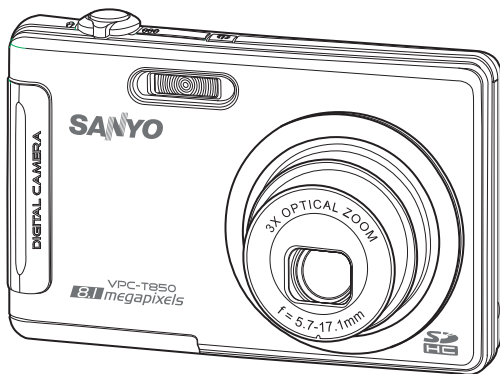

Please read these instructions carefully before using the camera.
Keep this manual in a safe place for later reference.

FCC STATEMENT

This device complies with Part 15 of the FCC Rules. Operation is subject to the following two conditions:

- (1) This device may not cause harmful interference, and
- (2) This device must accept any interference received, including interference that may cause undesired operation.

Note:

This equipment has been tested and found to comply with the limits for Class B digital devices, pursuant to Part 15 of the FCC rules. These limits are designed to provide reasonable protection against harmful interference in a residential installation. This equipment generates uses and can radiate radio frequency energy and, if not installed and used in accordance with the instructions, may cause harmful interference to radio communications. However, there is no guarantee that interference will not occur in a particular installation. If this equipment does cause harmful interference to radio or television reception, which can be determined by turning the equipment off and on, the user is encouraged to try to correct the interference by one or more of the following measures:

- Reorient or relocate the receiving antenna.
- Increase the separation between the equipment and receiver.
- Connect the equipment into an outlet on a circuit different from that to which the receiver is connected.
- Consult the dealer or an experienced radio/TV technician for help.

Use of shielded cable is required to comply with Class B limits in Subpart B of Part 15 of the FCC rules.

Do not make any changes or modifications to the equipment unless otherwise specified in the manual. If such changes or modifications should be made, you could be required to stop operation of the equipment.

Notice

If static electricity or electromagnetism causes data transfer to discontinue midway (fail), restart the application or disconnect and connect the communication cable (USB, etc.) again.

READ THIS FIRST

Trademark Information

- Microsoft® and Windows® are U.S. registered trademarks of Microsoft Corporation.
- Pentium® is a registered trademark of Intel Corporation.
- Macintosh is a trademark of Apple Inc.
- SD™ is a trademark.
- SDHC™ is a trademark.



- Other names and products may be trademarks or registered trademarks of their respective owners.

Product Information

- Product design and specifications are subject to change without notice. This includes primary product specifications, software, software drivers, and user's manual. This User Manual is a general reference guide for the product.
- The product and accessories that come with your camera may be different from those described in this manual. This is due to the fact that different retailers often specify slightly different product inclusions and accessories to suit their market requirements, customer demographics, and geographical preferences. Products very often vary between retailers especially with accessories such as batteries, chargers, AC adapters, memory cards, cables, pouches, and language support. Occasionally a retailer will specify a unique product color, appearance, and internal memory capacity. Contact your dealer for precise product definition and included accessories.
- The illustrations in this manual are for the purpose of explanation and may differ from the actual design of your camera.
- The manufacturer assumes no liability for any errors or discrepancies in this user manual.

SAFETY INSTRUCTIONS

Read and understand all **Warnings** and **Cautions** before using this product.

Warnings

If foreign objects or water have entered the camera, turn the power off and remove the battery.

Continued use might cause fire or electric shock. Consult the store of purchase.



If the camera has fallen or its case has been damaged, turn the power off and remove the battery.

Continued use might cause fire or electric shock. Consult the store of purchase.



Do not disassemble, change or repair the camera.

This might cause fire or electric shock. For repair or internal inspection, ask the store of purchase.



Do not use the camera in areas near water.

This might cause fire or electric shock. Take special care during rain, snow, on the beach, or near the shore.



Do not place the camera on inclined or unstable surfaces.

This might cause the camera to fall or tilt over, causing damage.



Keep the battery out of the reach of children.

Swallowing the battery might cause poisoning. If the battery is accidentally swallowed, immediately consult a physician.



Do not use the camera while you are walking, driving or riding a motorcycle.

This might cause you to fall over or result in traffic accident.



Cautions

Insert the battery paying careful attention to the polarity (+ or -) of the terminals.

Inserting the battery with its polarities inverted might cause fire and injury, or damage to the surrounding areas due to the battery rupturing or leaking.



Do not fire the flash close to anyone's eyes.

This might cause damage to the person's eyesight.



Do not subject the LCD monitor to impact.

This might damage the glass on the screen or cause the internal fluid to leak. If the internal fluid enters your eyes or comes into contact with your body or clothes, rinse with fresh water. If the internal fluid has entered your eyes, consult a physician to receive treatment.



A camera is a precision instrument. Do not drop it, strike it or use excessive force when handling the camera.

This might cause damage to the camera.



Do not use the camera in humid, steamy, smoky, or dusty places.

This might cause fire or electric shock.



Do not remove the battery immediately after long period of continuous use.

The battery becomes hot during use. Touching a hot battery might cause burns.



Do not wrap the camera or place it in cloth or blankets.

This might cause heat to build up and deform the case, resulting in fire. Use the camera in a well-ventilated place.



Do not leave the camera in places where the temperature may rise significantly, such as inside a car.

This might adversely affect the case or the parts inside, resulting in fire.



Before you move the camera, disconnect cords and cables.

Failure to do this might damage cords and cables, resulting in fire and electric shock.



Warning:

TO PREVENT THE RISK OF FIRE OR ELECTRIC SHOCK, DO NOT EXPOSE THIS APPLIANCE TO RAIN OR MOISTURE

FOR AMERICAN USERS

The following advisory is included in accordance with the laws of the State of California (USA):

WARNING:

This product contains chemicals, including lead, known to the States of California to cause cancer, birth defects or other reproductive harm. ***Wash hands after handling.***

- This equipment has been tested and found to comply with the limits for a Class B digital device, pursuant to Part 15 of the FCC Rules. These limits are designated to provide reasonable protection against harmful interference in a residential installation. This equipment generates, uses and can radiate radio frequency energy and, if not installed and used in accordance with instructions, may cause harmful interference to radio communications. However, there is no guarantee that interference will not occur in a particular installation. If this equipment does cause harmful interference to radio or television reception, which can be determined by turning the equipment off and on, the user is encouraged to try to correct the interference by one or more of the following measures:
 - * Reorient or relocate the receiving antenna.
 - * Increase the separation between the equipment and receiver.
 - * Connect the equipment into an outlet on a circuit different from that to which the receiver is connected.
 - * Consult the dealer or an experienced radio/TV technician for help.
- Changes or modifications not expressly approved by the party responsible for compliance could void the user's authority to operate the equipment.

FOR CANADIAN USERS

- This Class B digital apparatus complies with Canadian ICES-003

FOR EU USERS



Note:

- This symbol mark and recycle system apply to EU countries and do not apply to countries in other areas of the world.

Your SANYO product is designed and manufactured with high quality materials and components which can be recycled and reused.

This symbol means that electrical and electronic equipment, at their end-of-life, should be disposed of separately from your household waste.

Please dispose of the equipment at your local community waste collection/recycling centre.

In the European Union there are separate collection systems for used electrical and electronic products.

Please help up to conserve the environment we live in!

Manufacturer and Address

SANYO Electric Co., Ltd.
5-5, Keihan-hondori, 2-chome,
Moriguchi City, Osaka, Japan

Authorized Representative and Address

SANYO FISHER Sales (Europe) GmbH
Stahlgruberring 4, D-81829 Munich, Germany

Symbols used in this manual



- Points giving some extended instructions or special points to pay attention to.

You may find the answers to questions or problems concerning camera operation in the sections “Troubleshooting”.

FCC information



Tested To Comply
With FCC Standards

FOR HOME OR OFFICE USE

Declaration of Conformity

Model number: VPC-T850

Trade Name: SANYO

Responsible party: SANYO FISHER COMPANY

Address: 21605 Plummer Street
Chatsworth, California 91311

Telephone No.: (818) 998-7322

This device complies with Part 15 of the FCC Rules. Operation is subject to the following two conditions:

- (1) this device may not cause harmful interference, and
- (2) this device must accept any interference received, including interference that may cause undesired operation.

Canadian ICES-003 information

This class B digital apparatus complies with Canadian ICES-003.

Notes on Battery Usage

When you use the battery, carefully read and strictly observe the **Safety Instructions** and the notes described below:

- Use only the specified battery (3.7V).
- Avoid extremely cold environments as low temperatures can shorten the battery life and reduce camera performance.
- When you are using a new rechargeable battery or a rechargeable battery that has not been used for an extended period of time, it may affect the number of images that can be captured. Therefore, to maximize its performance and lifetime, we recommend that you fully charge the battery and discharge it for at least one complete cycle before use.
- The battery may feel warm after a long period of continuous use of the camera or the flash. This is normal and not a malfunction.
- The camera may feel warm after a long period of continuous use. This is normal and not a malfunction.
- If the battery is not to be used for a long period of time, remove it from the camera to prevent leakage or corrosion and store it after no battery power is left. Stored for a long time in a fully charged condition, its performance may be impaired.
- Always keep the battery terminals clean.
- There is a risk of explosion if the battery is replaced by an incorrect type.
- Dispose of used battery according to the recycle instructions.
- Charge the rechargeable battery fully before using for the first time.
- To prevent short-circuiting or fire, keep the battery away from other metal objects when carrying or storing.

CAUTION

- Danger of explosion if battery is incorrectly replaced.
- Replace only with the same or equivalent type.

CONTENTS

10 INTRODUCTION

- 10 Overview
- 10 Package Contents

11 GETTING TO KNOW YOUR CAMERA

- 11 Front View
- 12 Rear View
- 13 LCD Monitor Display

15 GETTING START

- 15 Preparation
- 16 Charging the Battery
- 17 Initial Settings

19 CAPTURE MODE

- 19 Capturing Images
- 20 Recording Shots using Face Detection Technology
- 21 Recording Voice Memos

22 VIDEO MODE

- 22 Recording Video Clips
- 22 Playing Back Video Clips

23 PLAYBACK MODE

- 23 Playing Back Still Images
- 24 Thumbnail Display
- 24 Removing Red-eye
- 25 Attaching Voice Memos
- 26 Protecting Images
- 27 Erasing Images

28 MENU OPTIONS

- 28 Capture Menu
- 31 Video Menu
- 32 Playback Menu
- 33 Setup Menu

34 TRANSFERRING FILES TO YOUR COMPUTER

- 34 Downloading Your Files

35 USING THE CAMERA AS A PC CAMERA

36 EDITING SOFTWARE INSTALLATION

37 SPECIFICATIONS

38 APPENDIX

- 38 Possible Number of Shots
- 39 Troubleshooting
- 40 Connecting to a PictBridge Compliant Printer

INTRODUCTION

Overview

Congratulations on your purchase of the new digital camera.

Capturing high-quality digital images is fast and easy with this state-of-the-art smart camera. Equipped with a 8.1-megapixel CCD, this camera is capable of capturing images with a resolution of up to 3264 x 2448 pixels.

Package Contents

Carefully unpack your camera and ensure that you have the following items:

Common Product Components:

- Digital Camera
- Software CD-ROM
- USB cable
- AV cable
- Camera strap
- Camera pouch
- Rechargeable lithium-ion battery
- Battery charger
- AC adapter for battery charger
- Instruction manual

Optional Accessory:

- SD/SDHC memory card



-
- Accessories and components may vary by retailer.

GETTING TO KNOW YOUR CAMERA

Front View

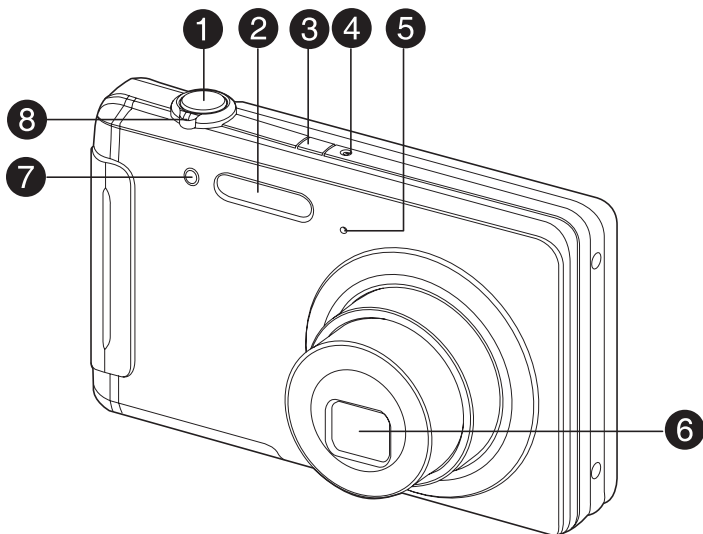

- 1. Shutter button
- 2. Flash
- 3.  Power button
- 4. Status LED
- 5. Microphone
- 6. Lens
- 7. Self-timer LED
- 8. Zoom lever

Rear View

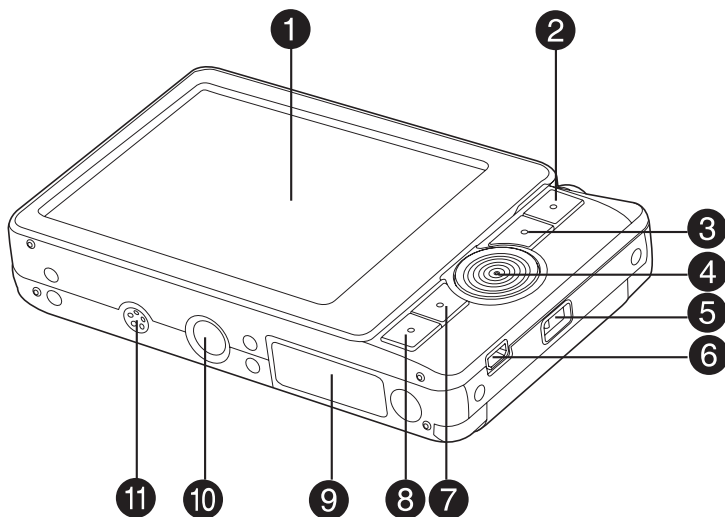

1. LCD monitor

2.  Mode button

3.  Menu button

4. Direction button

▲ button

 Focus button

▶ button

 Flash button

▼ button

 Self-timer button

 Delete button

◀ button

 Backlight / Exposure compensation button

5. Strap holder

6. USB or AV OUT terminal

7.  Set button

 Display button

8.  Playback button

9. Battery / Memory card cover

10. Tripod socket

11. Speaker

LCD Monitor Display

Capture mode

1. Zoom status
2. Voice memo
3. Battery condition
 - [Full battery icon] Full battery power
 - [Medium battery icon] Medium battery power
 - [Low battery icon] Low battery power
 - [No battery icon] No battery power
4. Flash mode
 - [Blank] Auto Flash
 - [Red-eye icon] Red-eye Reduction
 - [Pre-flash icon] Pre-flash
 - [Forced Flash icon] Forced Flash
 - [Flash Off icon] Flash Off
5. Storage media
 - [Internal memory icon] Internal memory (no card)
 - [SD/SDHC icon] SD/SDHC memory card
6. Histogram
7. Main focus area (When the shutter button is pressed halfway)
8. Image quality
 - [Fine icon] Fine
 - [Standard icon] Standard
 - [Economy icon] Economy
9. Image size resolution
 - [3264 x 2448 icon] 3264 x 2448
 - [2816 x 2112 icon] 2816 x 2112
 - [2272 x 1704 icon] 2272 x 1704
 - [1600 x 1200 icon] 1600 x 1200
 - [640 x 480 icon] 640 x 480
10. Available number of shots
11. ISO
 - [Blank] Auto
 - [ISO 64 icon] ISO 64
 - [ISO 100 icon] ISO 100
 - [ISO 200 icon] ISO 200
 - [ISO 400 icon] ISO 400
 - [ISO 800 icon] ISO 800
 - [ISO 1600 icon] ISO 1600
12. Self-timer icon
 - [2s icon] 2 sec.
 - [10s icon] 10 sec.
 - [10+2s icon] 10+2 sec.
13. Date and time
14. Exposure compensation
 - [Exposure compensation icon] Exposure compensation
 - [Backlight icon] Backlight correction
 (Adjust exposure value with the ◀ / ▶ buttons)
15. Capture mode icon
 - [Blank] Single
 - [Continuous icon] Continuous
 - [Auto Exposure Bracketing icon] Auto Exposure Bracketing

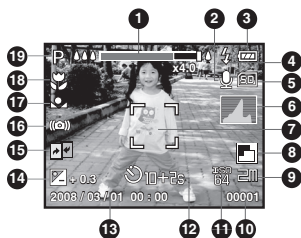

- [Burst Series+flash icon] Burst Series+flash
- [Pre-Shot icon] Pre-Shot
- [Couple Shot icon] Couple Shot
- 16. Slow shutter warning
- 17. White balance
 - [Blank] Auto
 - [Incandescent icon] Incandescent
 - [Fluorescent 1 icon] Fluorescent 1
 - [Fluorescent 2 icon] Fluorescent 2
 - [Daylight icon] Daylight
 - [Cloudy icon] Cloudy
 - [Manual icon] Manual
- 18. Focus setting
 - [Blank] Auto focus
 - [Face detection icon] Face detection
 - [Macro icon] Macro
 - [Infinity icon] Infinity
- 19. Scene mode
 - [Program AE icon] Program AE
 - [Anti Shake icon] Anti Shake
 - [Panorama icon] Panorama
 - [Portrait Man icon] Portrait Man
 - [Portrait Lady icon] Portrait Lady
 - [Landscape icon] Landscape
 - [Sports icon] Sports
 - [Night Portrait icon] Night Portrait
 - [Night Scene icon] Night Scene
 - [Candlelight icon] Candlelight
 - [Fireworks icon] Fireworks
 - [Text icon] Text
 - [Sunset icon] Sunset
 - [Sunrise icon] Sunrise
 - [Splash Water icon] Splash Water
 - [Flow Water icon] Flow Water
 - [Snow icon] Snow
 - [Beach icon] Beach
 - [Pets icon] Pets
 - [User Setting icon] User Setting

Video mode []

1. Zoom status
2. Flash mode
3. Battery condition
4. Storage media
5. Main focus area
6. Video quality
7. Video resolution
8. Available recording time/Elapsed time
9. Self-timer icon
10. Date and time
11. Focus setting
12. Mode icon

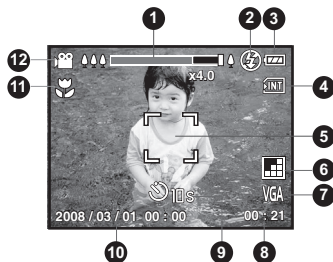

Playback mode [] - Still image playback

1. Voice memo
2. Battery condition
3. Storage media
4. Histogram
5. ISO
6. Image quality
7. Image size resolution
8. File number
9. Folder number
10. Date and time
11. Exposure value
12. Aperture value
13. Shutter speed value
14. Protect icon
15. Mode icon



Playback mode [] - Video playback

1. Video status bar
2. Elapsed time
3. File number
4. Folder number
5. Sound off icon (When the ▲ button is pressed during video playback)
6. Play mode
7. Mode icon
8. Total recorded time

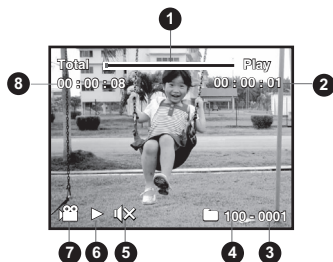

GETTING START

Preparation

1. Attach the camera strap.
2. Open the battery/memory card cover.
3. Insert the supplied battery with correct orientation as shown.
4. Insert an SD/SDHC memory card (Optional).
 - The camera has 32MB internal memory (28MB available for image storage), but you can load an SD/SDHC memory card to expand the camera's memory capacity.
 - Be sure to format the memory card with this camera before its initial usage.
5. Close the battery/memory card cover and make sure it is locked securely.

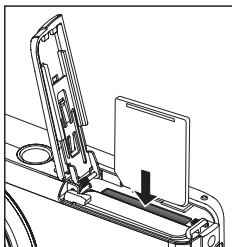
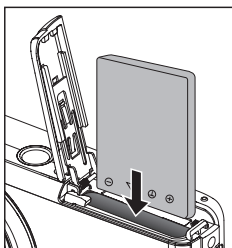
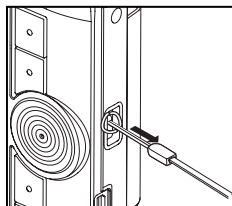

- To prevent valuable data from being accidentally erased from an SD/SDHC memory card, you can slide the write protect tab (on the side of the SD/SDHC memory card) to "LOCK".
- To save, edit, or erase data on an SD/SDHC memory card, you must unlock the card.
- To prevent damaging of an SD/SDHC memory card, be sure to turn off the power when inserting or removing the SD/SDHC memory card. If inserting or removing the SD/SDHC memory card with the power on, the camera will automatically turn off.

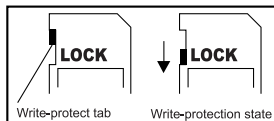

Charging the Battery

Charge the battery fully with the supplied battery charger before use.

1. Insert the battery into the battery charger.
2. Connect the power cord to the charger and insert the plug into a wall outlet.

- The status LED on the charger lights red when charging has started and lights green when charging is completed. The LED also lights green if no battery is inserted into the charger.
- Charging time varies according to the ambient temperature and the status of battery.
- Remove the battery after charging is completed.

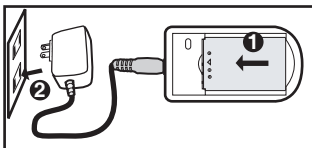

- The battery may feel warm after it has been charged or immediately after being used. This is normal and not a malfunction.
- When using the camera in cold areas, keep the camera and battery warm by holding them inside your outer clothes.

Initial Settings

Setting the Date and Time

The date/time needs to be set if and when:

- The camera is turned on for the first time.
- The camera is turned on after leaving the camera without the battery for an extended period of time.

When the date and time information is not displayed on the LCD monitor, follow these steps to set the correct date and time.

1. Press the **MODE** button to [📷] or [📹].
2. Press the **MENU** button.
3. Select [Setup] with the **▶** button.
4. Select [Date/Time] with the **▲ / ▼** buttons, and press the **SET DISP.** button.
5. Select the date format with the **▲ / ▼** buttons, and press the **SET DISP.** button.
 - Select the item's field with the **◀ / ▶** buttons and adjust the value for the date and time with the **▲ / ▼** buttons.
 - The time is displayed in 24-hour format.
 - After confirming all settings are correct, press the **SET DISP.** button.
6. To exit from the [Setup] menu, press the **MENU** button.

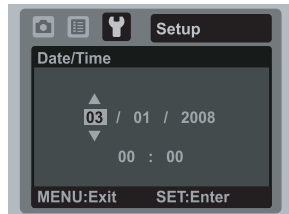
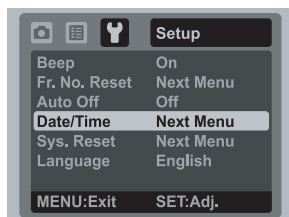

Choosing the Language

Specify in which language menus and messages are to be displayed on the LCD monitor.

1. Press the **MODE** button to [] or []; or press the [] button.
2. Press the **MENU** button.
3. Select [Setup] menu with the **▶** button.
4. Select [Language] with the **▲ / ▼** buttons and press the **SET DISP.** button.
5. Select the displayed language with the **▲ / ▼** buttons and press the **SET DISP.** button.
 - The setting will be stored.

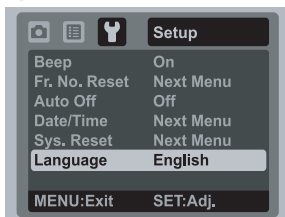

Formatting the Memory Card or Internal Memory

This utility formats the internal memory (or memory card) and erases all stored images and data.



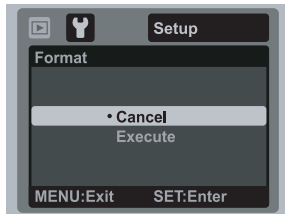
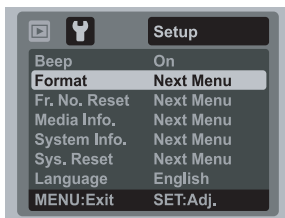





1. Press the [] button.
2. Press the **MENU** button.
3. Select [Setup] menu with **▶** button.
4. Select [Format] with the **▲ / ▼** buttons, then press the **SET DISP.** button.
5. Select [Execute] with the **▲ / ▼** buttons, and press the **SET DISP.** button.
 - To cancel formatting, select [Cancel] and press the **SET DISP.** button.



CAPTURE MODE

Capturing Images

Your camera is equipped with a 2.8" full color TFT LCD monitor to help you compose images, playback recorded images/video clips or adjust menu settings.

1. Press the  button to turn the power on.
 - The status LED lights green and the camera is initiated.
 - If the power is turned on in [] or [] mode, the lens will extend forward and it is ready for shooting. In both modes, if the camera mode is changed to [], the lens barrel will retract into the camera body after 30 seconds.
2. Press the  button to [].
3. Compose your image in the LCD monitor.
 - Slide the zoom lever to  side to zoom in on the subject, and enlarges the subject on the LCD monitor.
 - Slide the zoom lever to  side to zoom out on the subject, and provides a wider angle image.
4. Press the shutter button.
 - Pressing the shutter button down halfway automatically focuses and adjusts the exposure, and pressing the shutter button down fully captures the images.
 - The focus area frame turns green when the camera is in focus and the exposure is calculated.
 - When the focus or exposure is not suitable, the frame of the focus area turns red.

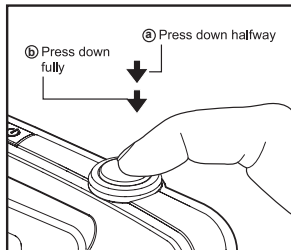

Recording Shots using Face Detection Technology

Face Detection Technology can identify and focus on the human faces in the image. This advanced function simultaneously detects up to 5 human faces regardless of their position in the scene.

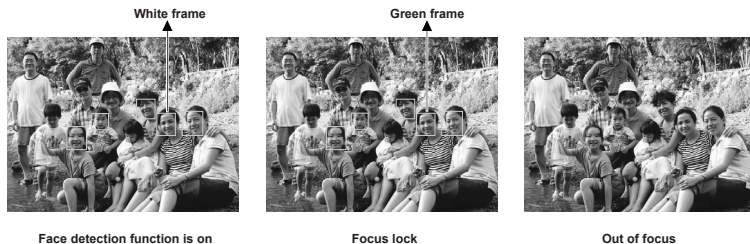













1. Press the **MODE** button to [].
2. Press the button until [] icon appears on the LCD monitor.
 - The white frame is identified as the “top priority” face (main focus frame), and gray ones around the other faces.
3. Press the shutter button halfway down to lock the focus.
 - The main focus frame simultaneously turns green.
 - If the “top priority” face is out of focus, all frames will be disappeared from the screen.
4. Press the shutter button down fully to capture your image.



- Subjects that are not suitable with this function:
 - a. A person is wearing glasses, sunglasses, or face is covered with hat or hair.
 - b. A person turned sideways.

Recording Voice Memos

A voice memo can be recorded once for 30 seconds in the still image mode immediately following a still image capture.

1. Press the  button to [].
2. Press the  button, and select the [Function] menu with the  button.
3. Select [Voice Memo] with the  /  buttons, and press the  button.
4. Select [On] with the  /  buttons, and press the  button.
5. Press the  button to exit from the menu.
 - An  icon is displayed on the screen.
6. Compose the image, press the shutter button down halfway, then press it down fully.
 - [VOICE RECORDING] is displayed on the screen immediately, and the voice memo recording starts.
7. Press the shutter button one more time during recording, or wait for 30 seconds.
 - [VOICE RECORD END] will be displayed and the recording will end.
 - An  icon is displayed with images that have been recorded with a voice memo.

VIDEO MODE

Recording Video Clips

This mode allows you to record video clips at a resolution of 320 x 240 / 640 x 480 pixels.

1. Press the **MODE** button to [📷].
2. Compose the image.
3. Press the shutter button.
 - The recording of the video clip will start.
 - Pressing the shutter button one more time will end the recording of the video clip.
 - The recording time depends on the storage size and the subject of the image to be recorded.
 - The zoom function cannot be used during video recording.

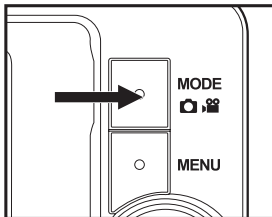

- When recording a video clip, the flash and "10+2 sec." self-timer function cannot be used.
- If the write speed of your SD/SDHC memory card is not fast enough for recording video clips in the currently selected quality, the video recording will stop. In this case, select a video quality lower than the current one.

Playing Back Video Clips

You can play back recorded video clips on the camera. You can also play back sound if recorded with the video.

1. Press the [▶] button.
 - The last image appears on the screen.
2. Select the desired video clip with the ◀ / ▶ buttons.
3. Press the **SET DISP** button.
 - A press of the ▶ / ◀ buttons during playback allows fast forward play / fast reverse play.
 - To stop video playback, press the ▼ button.
This stops playback and returns to the start of the video clip.
 - To pause video playback, press the **SET DISP** button.
This pauses video playback.
To cancel pause, press the **SET DISP** button again.



- Video clips cannot be displayed rotated or enlarged.
- Windows Media player or QuickTime Player is recommended to play back the video clip on your computer.
- QuickTime Player is a free media player available at www.apple.com; and compatible with Mac and Windows computers.
- For more information about the operation of the media player, refer to its respective help documentation.

PLAYBACK MODE

Playing Back Still Images

You can play back the still images on the LCD monitor.

1. Press the [▶] button.
 - The last image appears on the screen.
2. The images can be displayed in forward or reverse sequence with the ◀ / ▶ buttons.
 - To view the previous image, press the ◀ button.
 - To view the next image, press the ▶ button.
 - Pressing the ▲ button during image playback will result in a 90-degree clockwise rotation display.
 - Slide the zoom lever to ◯ side enlarges the image.
 - To return to normal magnification, slide the zoom lever to ∞ side.

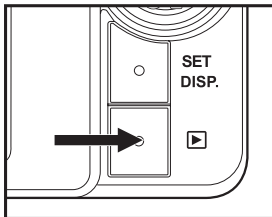

- An [📹] icon is displayed with the video data. Video clips cannot be rotated.
- An [🗣️] icon is displayed with images which have an audio memo recorded.

Thumbnail Display

This function allows you to view 9 thumbnail images on the LCD monitor at the same time, which can let you quickly search for the image that you want.

1. Press the [▶] button.
 - The last image appears on the screen.
2. Slide the zoom lever to $\frac{\infty}{000}$ side.
 - The images are displayed in the thumbnail display.
3. Press the ▲ / ▼ / ◀ / ▶ buttons to select the image to be displayed at regular size.
4. Press the $\frac{SET}{DISP}$ button.
 - The selected image is displayed at its regular size.

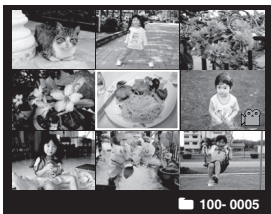

- An [⓪], [◀], [▶] icon may be displayed in a thumbnail.

Removing Red-eye

You can use this function to remove the red-eye effect after an image is taken.

1. Press the [▶] button.
2. Select the image that you want to edit with the ◀ / ▶ buttons.
3. Press the MENU button.
4. Select [Fix Red Eyes] with the ▲ / ▼ buttons, and press the $\frac{SET}{DISP}$ button.
5. Select [Execute] with the ▲ / ▼ buttons, and press the $\frac{SET}{DISP}$ button.
6. View the changes on the corrected image.
7. To save your corrected image, select [Confirm] with the ▲ / ▼ buttons, and press the $\frac{SET}{DISP}$ button.
 - When this process ends, this replaces the original image with the corrected image.

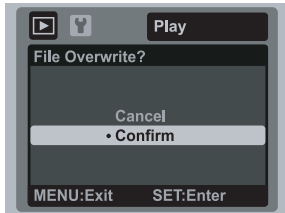

Attaching Voice Memos

A maximum of 30 seconds of audio can be recorded as a memo for captured still images. The voice memo can be recorded only once.

1. Press the [▶] button.
 - The last image appears on the screen.
2. Select the image to which you want to attach the voice memo with the ◀ / ▶ buttons.
3. Press the MENU button.
4. Select [Voice Memo] with the ▲ / ▼ buttons, and press the SET DISP. button.
5. Select [On] with the ▲ / ▼ buttons, and press the SET DISP. button.
6. Press the MENU button to exit from the menu.
7. Press the shutter button.
 - [VOICE RECORDING] is displayed on the screen and recording starts.
8. To stop recording a voice memo as it is being recorded, press the shutter button again.
 - [VOICE RECORD END] will be displayed and the recording will end. An [🎤] icon is displayed with images that have been recorded with a voice memo.

Playing back voice memo

A press of the shutter button displays [VOICE PLAYBACK] and plays back the voice memo.



-
- Voice memo is only available for still images.

Protecting Images

Set the data to read-only to prevent images from being erased by mistake.

1. Press the [] button.
2. Select the image that you want to protect with the ◀ / ▶ buttons.
3. Press the MENU button.
4. Select [Protect] with the ▲ / ▼ buttons, and press the SET DISP. button.
5. Select [Single] or [All] with the ▲ / ▼ buttons, and press the SET DISP. button.
6. Select [Set] with the ▲ / ▼ buttons, and press the SET DISP. button.
 - Protection is applied to the image and the camera returns to the playback mode.
 - The protect icon [] is displayed with protected images. When [All] has been selected, [] is displayed with all the images.



Canceling the Protection

To cancel protection for only one image, display the image on which you want to remove the image protection.

1. Select [Protect] with the ▲ / ▼ buttons from the playback menu, and press the SET DISP. button.
2. Select [Single] or [All] with the ▲ / ▼ buttons, and press the SET DISP. button.
3. Select [Cancel Protect] with the ▲ / ▼ buttons, and press the SET DISP. button.
 - The removal of image protection is executed and the camera returns to the playback mode.



Protecting multiple images simultaneously

1. Select [Protect] with the ▲ / ▼ buttons from the playback menu, and press the SET DISP. button.
 - The images are displayed in the thumbnail display.
2. Select [Select] with the ▲ / ▼ buttons, and press the SET DISP. button.
 - The protect icon [] is displayed with protected images. One more press of the ▼ button will cancel the operation. This procedure is repeated to select multiple images.
3. Select the image you want to protect with the ◀ / ▶ buttons, and press the ▼ button.
 - The protect icon [] is displayed with protected images. One more press of the ▼ button will cancel the operation. This procedure is repeated to select multiple images.
4. Press the SET DISP. button.
5. Select [Execute] with the ▲ / ▼ buttons, and press the SET DISP. button.
 - Protection is executed and the camera returns to playback mode.



- Formatting an SD/SDHC memory card overrides protection, and erases all images regardless of their protected status.



Erasing Images

Erasing single image / Erasing all images

1. Press the [▶] button.
2. Select the image you want to erase with the ◀ / ▶ buttons.
3. Press the  button.
4. Select [Single] or [All] with the ▲ / ▼ buttons, and press the ^{SET}_{DISP.} button.
 - [Single]: Erases the selected image or the last image.
 - [All]: Erases all of the images except for the protected images.
 - [Select]: Erases a number of selected images.
5. Select [Execute] with the ▲ / ▼ buttons, and press the ^{SET}_{DISP.} button.
 - To not erase, select [Cancel], and press the ^{SET}_{DISP.} button.

Erasing selected images

This erases a number of selected images.

1. Press the [▶] button.
2. Press the  button.
3. Select [Select] with the ▲ / ▼ buttons, and press the ^{SET}_{DISP.} button.
 - The images are displayed in the thumbnail display.
4. Select the image you want to erase with the ◀ / ▶ buttons, and press the ▼ button.
 - The [] icon will be displayed. One more press of the ▼ button will cancel the operation. Repeat this procedure and select all the images that you want to erase.
5. Press the ^{SET}_{DISP.} button.
6. Select [Execute] with the ▲ / ▼ buttons, and press the ^{SET}_{DISP.} button.



- Deleting an image will not affect sequential image numbering. For example, if you delete image number 240, the next captured image will be numbered 241 even though 240 no longer exists. In other words, an image-number is retired when an image is deleted and will not be reused or reassigned to another subsequently captured image.

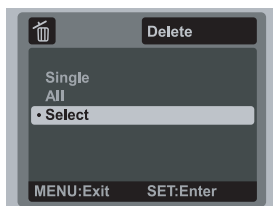
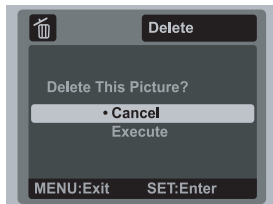

MENU OPTIONS

Capture Menu

This menu is for the basic settings to be used when capturing still images.

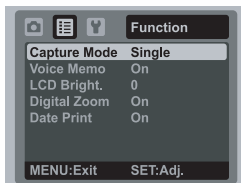
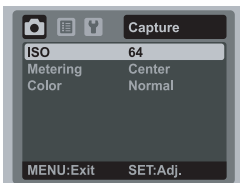

1. Press the **MODE** button to [].
2. Press the **MENU** button, and select the [Capture] / [Function] menu with the **◀** / **▶** buttons.
3. Select the desired option item with the **▲** / **▼** buttons, and press the **SET DISP.** button to enter its respective menu.
4. Select the desired setting with the **▲** / **▼** buttons, and press the **SET DISP.** button.
5. To exit from the menu, press the **MENU** button.

Scene Mode

Select from 20 different scene modes in accordance with the shooting conditions.

* Program AE / Anti Shake / Panorama / Portrait Man / Portrait Lady / Landscape / Sports / Night Portrait / Night Scene / Candlelight / Fireworks / Text / Sunset / Sunrise / Splash Water / Flow Water / Snow / Beach / Pets / User Setting

Size

This sets the size of the image that will be captured.

- * [] 3264 x 2448
- * [] 2816 x 2112
- * [] 2272 x 1704
- * [] 1600 x 1200
- * [] 640 x 480

Quality

This sets the quality (compression) at which the image is captured.

- * [] Fine
- * [] Standard
- * [] Economy

Sharpness

This sets the sharpness of the image that will be captured.

- * Hard / Normal / Soft







Saturation

This sets the saturation of the image that will be captured.

- * High / Normal / Low

White Balance

This sets the white balance for a variety of lighting conditions and permits images to be captured that approach the conditions that are seen by the human eye.

- * [Blank] Auto
- * [] Incandescent
- * [] Fluorescent 1
- * [] Fluorescent 2
- * [] Daylight
- * [] Cloudy
- * [] Manual

Manual WB







This manually sets the white balance and stores it. Use of this is convenient when the white balance does not offer a good match.

Before selecting [Execute] and before taking your image, place a white paper in the scene and set the white balance manually.

- * Cancel / Execute

ISO

This sets the sensitivity for capturing images. When the sensitivity is raised (and the ISO figure is increased), photography will become possible even in dark locations, but the more pixelated (grainier) the image will appear.

- * [Blank] Auto
- * [] ISO 64
- * [] ISO 100
- * [] ISO 200
- * [] ISO 400
- * [] ISO 800
- * [] ISO 1600

Metering

This sets the metering method for calculating the exposure.

- * Center: Averages the light metered from the entire frame, but gives greater weight to the subject matter at the center.
- * Multi: The entire area of the screen is measured, and the exposure is calculated.
- * Spot: A very small portion of the center of the screen is measured to calculate the correct exposure.







Color

This sets the color of the image that will be captured.

- * Normal / Vivid / Sepia / Monochrome / Blue / Red / Green / Yellow / Purple

Capture Mode

This sets the recording method at the time of capturing images.

- * [Blank] Single: Captures one image at a time.
- * [] Continuous: Permits continuous capture of up to 3 images.
- * [] AEB: Permits 3 consecutive images in the order of standard exposure, underexposure and overexposure compensation.
- * [] Burst: Permits continuous photography while pressing holding the shutter button. As long as you hold the shutter button pressed, images are captured until the memory capacity is exhausted.
- * [] Series+flash: Permits continuous capture of up to 3 images with flash.
- * [] Pre-Shot: Lets you capture the background first, then have someone to capture you in front of it.
- * [] Couple Shot: Uses separate areas to combine two shots. You can include yourself in the shot.



-
- In [Continuous], [AEB], [Burst], [Series+flash], [Pre-Shot] and [Couple Shot] capture mode, the [Voice Memo] is automatically fixed at [Off].

Voice Memo

Refer to section in this manual titled "Recording Voice Memos" for further details.

LCD Bright.

Select a brightness level for the LCD monitor.

The LCD becomes brighter with the ▲ button and darker with the ▼ button. The adjustment range is from -5 to 5.

Digital Zoom

This sets whether or not to use digital zoom at the time of photography.

- * On / Off

Date Print

The date of recording can be printed directly on the still images. This function must be activated before the image is captured.

- * On / Off

Video Menu

This menu is for the basic settings to be used when recording video clips.

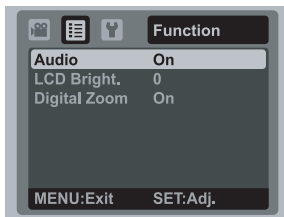
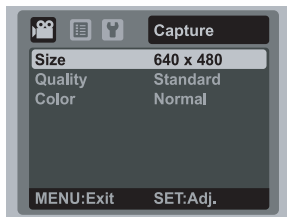

1. Press the **MODE** button to [**MODE**].
2. Press the **MENU** button, and select the [Capture] / [Function] menu with the **◀ / ▶** buttons.
3. Select the desired option item with the **▲ / ▼** buttons, and press the **SET DISP.** button to enter its respective menu.
4. Select the desired setting with the **▲ / ▼** buttons, and press the **SET DISP.** button.
5. To exit from the menu, press the **MENU** button.

Size

This sets the size of the video clip that will be captured.

* [**VGA**] 640 x 480

* [**VGA**] 320 x 240

Quality

This sets the quality (compression) at which the video clip is captured.

* [**Fine**] Fine

* [**Standard**] Standard

Color

This sets the color of the video clip that will be captured.

* Normal / Vivid / Sepia / Monochrome / Blue / Red / Green / Yellow / Purple

Audio

This sets whether or not to record audio at the time of video recording.

* On / Off

LCD Bright.

Refer to section in this manual titled "LCD Bright." in Capture Menu for further details.

Digital Zoom

Refer to section in this manual titled "Digital Zoom" in Capture Menu for further details.

Playback Menu

In the [] mode, choose which settings are to be used for playback.



1. Press the [] button.
2. Press the MENU button.
3. Select the desired option item with the ▲ / ▼ buttons, and press the SET DISP. button to enter its respective menu.
4. Select the desired setting with the ▲ / ▼ buttons, and press the SET DISP. button.
5. To exit from the menu, press the MENU button.

Fix Red Eyes

Refer to section in this manual titled “Removing Red-eye” for further details.

Slide Show

This function enables you to playback your still images automatically in order one image at a time.

* 3 sec. / 5 sec. / 10 sec.

Protect

Refer to section in this manual titled “Protecting Images” for further details.

Voice Memo

Refer to section in this manual titled “Attaching Voice Memos” for further details.

LCD Bright.

Refer to section in this manual titled “LCD Bright.” in Capture Menu for further details.

Resize

Resizes a previously saved image. Resizing replaces the original image with the changed image. It is only possible to resize to a smaller size.

Quality

Changes the quality (compression) of a recorded image. Compresses images down to half of their size or less, overwrites old size images with newly compressed images. It is only possible to reduce the image quality/size, never to increase it.

Copy to Card

Allows you to copy your files from the camera’s internal memory to an SD/SDHC memory card. Of course, you can only do this if you have a memory card installed and some files in internal memory.

* Cancel / Execute

Setup Menu

Set your camera's operating environment.

1. Toggle the ^{MODE} button to [] or []; or press the [] button.
2. Press the MENU button, and select the [Setup] menu with the ► button.
3. Select the desired option item with the ▲ / ▼ buttons, and press the ^{SET} _{DISP} button to enter its respective menu.
4. Select the desired setting with the ▲ / ▼ buttons, and press the ^{SET} _{DISP} button.
5. To exit from the menu, press the MENU button.

Beep

This sets whether or not to mute the camera sound each time you press the camera's buttons.

* On / Off

Fr. No. Reset

This creates a new folder. The captured images are recorded to the newly created folder from number 0001.

* Cancel / Execute

Auto Off

If no operation is performed for a specific period of time, the power to the camera is automatically turned off. This feature is useful for reducing battery usage.

* 1 Min. / 2 Min. / 3 Min. / Off

Date/Time

Refer to section in this manual titled "Setting the Date and Time" for further details.

Sys. Reset

This returns all basic settings to the camera's default settings. The time setting will not be reset.

* Cancel / Execute

Language

Refer to section in this manual titled "Choosing the Language" for further details.

Format

Refer to section in this manual titled "Formatting the Memory Card or Internal Memory" for further details.

Media Info.

This displays the free capacity of the internal memory or the memory card.

System Info.

This displays the firmware version of the camera.

Video Output

This sets your camera to match the system of the equipment that you are going to connect to the camera.

* PAL / NTSC

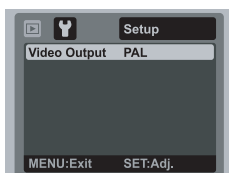
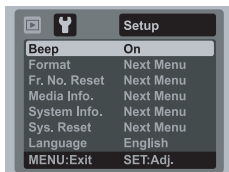
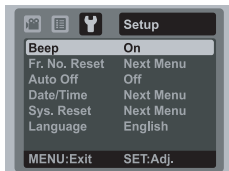

TRANSFERRING FILES TO YOUR COMPUTER

System Requirement

Windows	Macintosh
<ul style="list-style-type: none">■ Pentium III 600 MHz or higher■ Windows 2000/XP/Vista■ 128MB RAM■ 128MB hard disk space■ CD-ROM drive■ Available USB port	<ul style="list-style-type: none">■ PowerPC G3/G4/G5■ OS 9.0 or later■ 128MB RAM■ 128MB hard disk space■ CD-ROM drive■ Available USB port

Downloading Your Files

1. Connect one end of the USB cable to an available USB port on your computer.
2. Connect the other end of the USB cable to the USB terminal on the camera.
3. Turn on your camera.
4. Select [PC] using the ▲ / ▼ buttons and press the SET
DISP. button.
5. From the Windows desktop, double click on "My Computer".
6. Look for a new "removable disk" icon.
 - This "removable disk" is actually the memory (or memory card) in your camera. Typically, the camera will be assigned drive letter "e" or higher.
7. Double click on the removable disk and locate the DCIM folder.
8. Double click on the DCIM folder to open it to find more folders.
 - Your recorded images and video clips will be inside these folders.
9. Copy & Paste or Drag-N-Drop image and video files to a folder on your computer.

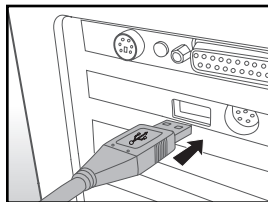

Mac users: Double-click the "untitled" or "unlabeled" disk drive icon on your desktop. iPhoto may automatically launch.

USING THE CAMERA AS A PC CAMERA

Your camera can act as a PC camera, which allows you to videoconference with business associates, or have a real-time conversation with friends or family. To use the camera for videoconferencing, your computer system must include the items as below:

- Microphone
 - Sound card
 - Speakers or headphones
 - Network or Internet connection
1. After installing the PC camera driver (included on the CD-ROM) in your Windows operating system, restart your computer.
 2. Connect one end of the USB cable to the USB terminal of the camera.
 3. Connect the other end of the USB cable to an available USB port on your computer.
 4. Turn on your camera.
 5. Select [PC Camera] with the ▲ / ▼ buttons and press the SET
DISP. button.
 6. Position the camera steadily on top of your computer monitor or use a tripod.
 7. Launch the videoconferencing application software.
 - Simply follow the instructions in the application software to start your camera.



-
- This function is not supported by Mac.
 - You are recommended to use MediaOne Gallery SE (included on the CD-ROM) or Windows Netmeeting (Windows Meeting Space on Windows Vista) as a videoconferencing application software.
 - The video resolution for videoconferencing applications is generally 320 x 240.
 - For more information about the operation of videoconference application software, refer to its respective help documentation.

EDITING SOFTWARE INSTALLATION

There are 2 types of software that are included on the CD-ROM:

MediaOne Gallery SE - makes it the easiest way to manage and share your digital life with family & friends. The intuitive thumbnail library automatically organizes, updates and sorts files for the most natural way to browse your multimedia collection.

COOL 360 SE - combines ease-of-use, power and flexibility to allow even novice digital imaging enthusiasts to move beyond traditional photos into immersive imaging. Its intuitive interface and easy-to-use wizard deliver great-looking panoramas while advanced warping, blending and alignment tools ensure excellent results.

To install software:

1. Insert the CD-ROM that came with the camera into your CD-ROM drive.
The welcome screen appears.
2. Click the respective software name.
Follow the on-screen instructions to complete the installation.



-
- For more information about the operation of the software, refer to its respective help documentation.
 - For Windows 2000/XP/Vista users, please make sure to install and use the software in "Administrator" mode.
 - The software is not supported by Mac.
 - COOL 360 SE is not supported by Windows Vista.

SPECIFICATIONS

Item	Description
Image sensor	1/2.5" CCD sensor (8.1 megapixels)
Image resolution	<Still image> 3264 x 2448, 2816 x 2112, 2272 x 1704, 1600 x 1200, 640 x 480 <Video clip> 640 x 480 (30 fps), 320 x 240 (30 fps)
LCD monitor	2.8" full color TFT LCD (230K pixels)
Recording media	32MB internal memory (28MB available for image storage) Supports SD/SDHC memory card (up to 4GB) (optional)
File format	JPEG, DCF 1.1, EXIF 2.2, AVI
Lens	3x optical zoom lens Aperture range: 2.9(W) - 5.2(T) Focal length:5.7mm - 17.1mm (equivalent to 34mm - 102mm on a 35mm camera)
Focus Range	Standard 0.4m to infinity Macro Wide: 0.1m to infinity Tele: 0.35m to infinity
Shutter speed	1/2 - 1/2000 sec.
Sensitivity	<Still image> Auto (ISO 64-200) Manual (ISO 64/100/200/400/800/1600) * Sensitivity is measured in compliance with the ISO standard (ISO12232:2006).
Digital zoom	4x (Capture mode) 4x (Playback mode)
Flash effective range	0.5m - 2.4m (Wide) 0.5m - 2.1m (Tele)
Terminals	AV OUT USB 2.0 compliant (2 in 1 terminal)
Power supply	Rechargeable Lithium-ion battery (3.7V)
Operating environment	Temperature: 0°C - 40°C (32°F to 104°F) Humidity: 10% - 85% (Non-condensing)
Dimensions	Approx. 92.8 x 57.8 x 18.7mm (without protruding parts)
Weight	Approx. 114g (without battery and memory card)





















* Design and specifications are subject to change without notice.

APPENDIX





Possible Number of Shots

Possible number of shots (still image)

The table shows the approximate shots that you can capture at each setting based on the capacity of the internal memory and the SD/SDHC memory card.

Size	Quality	Internal Memory	SD/SDHC memory card capacity					
			128MB	256MB	512MB	1GB	2GB	4GB SDHC
 3264 x 2448	 Fine	6	28	89	117	235	472	945
	 Standard	14	62	125	253	507	1015	2033
	 Economy	16	72	146	293	588	1177	2357
 2816 x 2112	 Fine	14	62	126	253	508	1018	2038
	 Standard	18	82	166	334	669	1340	2684
	 Economy	20	90	181	364	730	1461	2925
 2272 x 1704	 Fine	25	108	219	440	881	1765	3533
	 Standard	27	121	243	489	980	1963	3929
	 Economy	31	138	278	559	1120	2242	4489
 1600 x 1200	 Fine	47	206	415	834	1671	3345	6695
	 Standard	57	246	494	993	1989	3982	7969
	 Economy	63	273	549	1102	2208	4420	8847
 640 x 480	 Fine	118	509	1024	2055	4115	8237	16485
	 Standard	138	595	1197	2401	4810	9627	19268
	 Economy	177	762	1531	3072	6153	12316	24649

Possible recording time / sec (video clip)

Size	Quality	Internal Memory	SD/SDHC memory card capacity					
			128MB	256MB	512MB	1GB	2GB	4GB SDHC
VGA 640 x 480	 Fine	00:00:17	00:01:00	00:02:01	00:04:03	00:08:07	00:16:15	00:32:31
	 Standard	00:00:18	00:01:06	00:02:13	00:04:27	00:08:54	00:17:50	00:35:42
 320 x 240	 Fine	00:00:50	00:02:57	00:05:57	00:11:56	00:23:55	00:47:52	01:35:49
	 Standard	00:00:57	00:03:25	00:06:54	00:13:50	00:27:43	00:55:29	01:51:02

* We recommend a memory card of at least 10MB/Sec write speed to prevent auto stop or unexpected results. If you experience an error using a slower SD/SDHC memory card, you can set your camera's video recording to QVGA (320 x 240) and standard quality.

Troubleshooting

Refer to the symptoms and solutions listed below before sending the camera for repairs. If the problem persists, contact your local reseller or service center.

Symptom	Cause	Solutions / Corrective Actions
The power does not come on.	The battery is not inserted.	Insert the battery correctly.
	The battery is exhausted.	Recharge the battery.
The battery runs out quickly.	The battery is not fully charged. The battery is not used for an extended period of time after being charged.	Fully charge the battery and discharge it for at least one complete cycle before use to maximize its performance and lifetime.
The battery or camera feels warm.	Long period of continuous use of the camera or the flash.	
Even if I press the shutter button, the camera does not take a picture.	The shutter button is not pressed all the way down.	Press the shutter button all the way down.
	The memory card does not have any free capacity.	Insert a new memory card, or delete unwanted files.
	The memory card is write-protected.	Remove the write-protection.
Images do not appear on the LCD monitor.	LCD monitor is dark.	Adjust the brightness of the LCD monitor in the menu.
Although it is set to auto focus, it does not focus.	The lens is dirty.	Wipe clean with a soft, dry cloth or lens paper.
	The distance to the subject is smaller than the effective range.	Get your subject within the effective focus range.
The contents on the memory card cannot be played back.	You played back a memory card that was not formatted by this camera.	Insert a memory card that was formatted on this camera.
Files cannot be deleted.	The file is protected.	Cancel protection.
	The memory card is write-protected.	Remove the write-protection.
Even when the camera's buttons are pressed, it does not operate.	The battery is running low.	Recharge the battery.
The date and time are wrong.	The correct date and time is not set.	Set the correct date and time.
Cannot download images.	The free space on the hard disk in your computer may be insufficient.	Check whether the hard disk has space for running Windows, and if the drive for loading image files has a capacity at least that of the memory card inserted in the camera.
	No power supply.	Recharge the battery.

Connecting to a PictBridge Compliant Printer

If a printer that supports PictBridge is available, images can be printed by connecting the digital still camera directly to the PictBridge-compatible printer without using a computer.

Connecting the camera to the printer

1. Connect one end of the USB cable to your camera.
2. Connect the other end of the USB cable to the USB port on the printer.
3. Turn on your camera.
4. The [USB] screen is displayed. Select [PictBridge] with the \blacktriangle / \blacktriangledown buttons, and press the SET_{DISP} button.

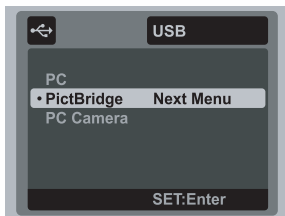

Printing images

When the camera is properly connected to a PictBridge compliant printer, the PictBridge menu is displayed on the monitor.

1. Select the item you want to configure with the \blacktriangle / \blacktriangledown buttons, and press the SET_{DISP} button.
 - [Images]: Select whether you want to print specific image or all images. You may also select printing number for specific image.
 - [Date Print]: According to the printer type, select whether you want to print the image with date imprint or not.
 - [Paper Size]: Select the desired paper size according to the printer type.
 - [Layout]: Select the desired printing layout according to the printer type.
 - [Print]: After all settings are configured, select this item to start printing.
2. If you select [Images] in the previous step, the figure shown on the right hand side will appear. Select [Single] or [All] with the \blacktriangle / \blacktriangledown buttons, and press the SET_{DISP} button.
 - [Single]: Select to print one specific image.
 - [All]: Select to print all images.
 - [Exit]: Exit from Images option.

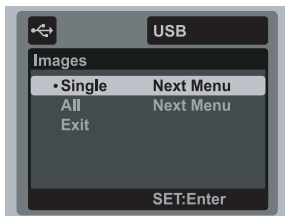
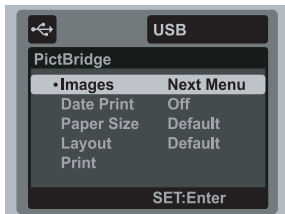

- If you select [Single] in the previous step, the figure shown on the right hand side will appear.
 - Select the image that you want to print with the ◀ / ▶ buttons.
 - Select the [Print Num] (up to 99) with the ▲ / ▼ buttons.
 - After selecting the desired image and printing number, press the SET_{DISP} button to confirm.
- Select [Exit] with the ▲ / ▼ buttons, and press the SET_{DISP} button.

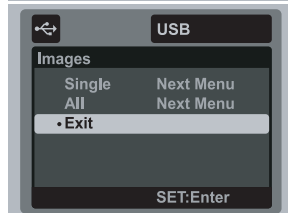
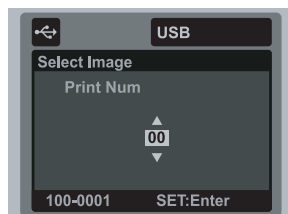

- Select [Print] with the ▲ / ▼ buttons, and press the SET_{DISP} button to start printing.

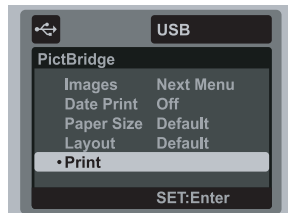

- The printing starts and the figure shown on the right hand side appears.
 - [COMPLETE] will be displayed temporarily, reminding you that the printing procedure is finished.
 - If an error is detected during the connection (i.e. the printer hardware problem) between camera and printer, [PRINT ERROR] will be displayed.
 - If an error is detected during the communication (i.e. wrong setting on the camera) between camera and printer, [ERROR] will be displayed.

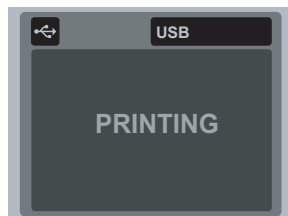

- The image printing may fail if the power to the camera is cut off.



SANYO Electric Co., Ltd.
Printed in China